



STR.02.07.000 MOUNTAIN MOTOR VACUUM PUMP INSTRUCTIONS

The Star Machine Mountain Motor Vacuum Pump is specifically designed to satisfy vacuum requirements in engine applications where flow requirements exceed traditional vacuum pumps. These applications include large CID's, and engines using enhancements such as Nitrous Oxide, superchargers or turbochargers.

MOUNTING THE PUMP

All effort should be made to utilize the Star Machine gold anodized mounting bracket. Use all ten (10) screws provided with the bracket to secure the pump to the mounting bracket. The mounting bracket should be positioned to allow for proper belt tensioning. should be mounted with the tubes facing straight up when possible for optimum pump performance.

DRIVING THE PUMP

There are many pulley/belt tooth configurations available today. We have chosen one of the most commonly found on race cars with .50" wide x .375" (L) pitch belts and pulleys. You may use another style as long as you follow the recommended ratios. If you chose to change the pulley on the Pump, you **MUST** use the pulley thrust cap delivered with your pump! This requires the use of a pulley (or pulley and spacer) with a combined hub width of .85" to .80" to ensure that the thrust cap will not bottom out on the shaft face. Use **ONLY ONE** set screw, directly over the key. Tighten the thrust cap first, then the set screw.

PUMP DRIVE RATIOS & VACUUM REGULATION

Satisfactory results can be realized by turning this pump much slower than traditional vacuum pumps. Ideal speeds are in the 3000-4000 RPM range. The maximum recommended pump speed is 5000 RPM. The factors used to determine the ideal drive ratio are engine displacement, engine RPM range, the presence of enhancements that increases blow-by and the amount of vacuum desired. Excessive Pump speeds that develop excessive levels of vacuum could be detrimental. Although slower Pump speeds will alleviate this condition, it could create a disadvantage at low RPM's, especially in applications where starting line RPM is low. Star Machine recommends the use of a vacuum regulator on most engines to address this condition. Some fitting plates contain a port for a vacuum regulator. The port is plugged off or not available on the plate if a regulator is not used. The regulator can be set at an ideal vacuum level for your particular application, insuring that vacuum levels will not exceed desired limits. Automatic transmission equipped cars may benefit from the use of a check valve. The check valve will help to maintain vacuum levels developed during the burnout process that may otherwise escape due to low engine RPM's during the staging process.

PLUMBING THE PUMP

Three fitting options are available for this pump: -12 A/N fittings, -16 A/N fittings or 1" tubes for use with -16 hose. They should be specified when ordering the pump, but can be changed later. The same considerations should be given to plumbing the Vacuum Pump as you would when plumbing your fuel system. Keep the hose lengths as short as possible. Minimize the use of right angle fittings. Free flowing, large radius bends are best. The use of springs inside of a hose to prevent from collapsing will disrupt airflow and may become loose and be drawn into the Pump. We recommend (and have available) a see-thru hose designed specifically for high vacuum systems. This clear hose will also give you an early indication if oil is being drawn out of the engine and into the Pump.

OPTIMIZING PERFORMANCE

The most overlooked aspect of successful crankcase vacuum is excessive leakage due to poor gaskets and seals and excessive blow-by. The ideal drive ratio can NEVER be achieved if excess pump speed is necessary to overcome leaks. Even the most careful engine assemblers can take for granted areas they never thought to be a problem. Pressure testing the engine for leakage must be done if optimum results are to be realized. Unlike fuel or coolant leaks that are obvious to the eye, vacuum leaks are not visible and consequently assumed to be nonexistent.

THINGS TO AVOID

OIL IN THE PUMP

The Pump is an "OIL-LESS" design, which requires NO LUBRICATION for operation. Oil in the Pump will not damage the Pump, however it will reduce its performance. The drier you can keep this Pump, the better it will work! The use of a baffle is mandatory! This may require several modifications to the location and design of the baffle you draw vacuum from. How will you know if oil is in the pump? If you use clear hose and the hose shows signs of oil in it, the oil will be in the Pump also. If you remove the belt from the Pump and spin it by hand and you do not hear the vanes tapping (as they are flung from the rotor) you have oil in the Pump. To clean the oil from the Pump, remove the hose from the intake side of the Pump and spray nonflammable (environmentally safe) solvent into the intake tube with the engine running. Mind the Pump exhaust when doing this! You should make this part of your usual race car maintenance.

Excessive oil in the pump is usually a clear indication of a failed seal or gasket.

DIRT IN THE PUMP:

During installation and storage use the caps supplied to cover the intake and exhaust tubes.

TOUCHING THE PUMP AFTER A RUN:

As a result of friction, heated intake air and the compression of the air within the Pump, it will be very hot (300+ degrees F).

ARTIFICIALLY COOLING THE PUMP:

ALLOW THE PUMP TO COOL NATURALLY

Do not blow air, place ice packs or pour water on the Pump to cool it.

DO NOT PLACE OBJECTS IN THE INT. OR EXH. PORTS WHILE THE PUMP IS RUNNING

(Especially your fingers)

**FOR MORE DETAILED INFORMATION ON ALL OUR PRODUCTS VISIT US AT
STARVACUUMPUMPS.COM**

STAR MACHINE
7810 OAK AVENUE
PARKVILLE, MARYLAND 21234

PHONE: 667.210.3874
FAX: 410.661.2467
EMAIL: STARVACUUMPUMPS@GMAIL.COM

INTAKE #2 OR REGULATOR LOCATION

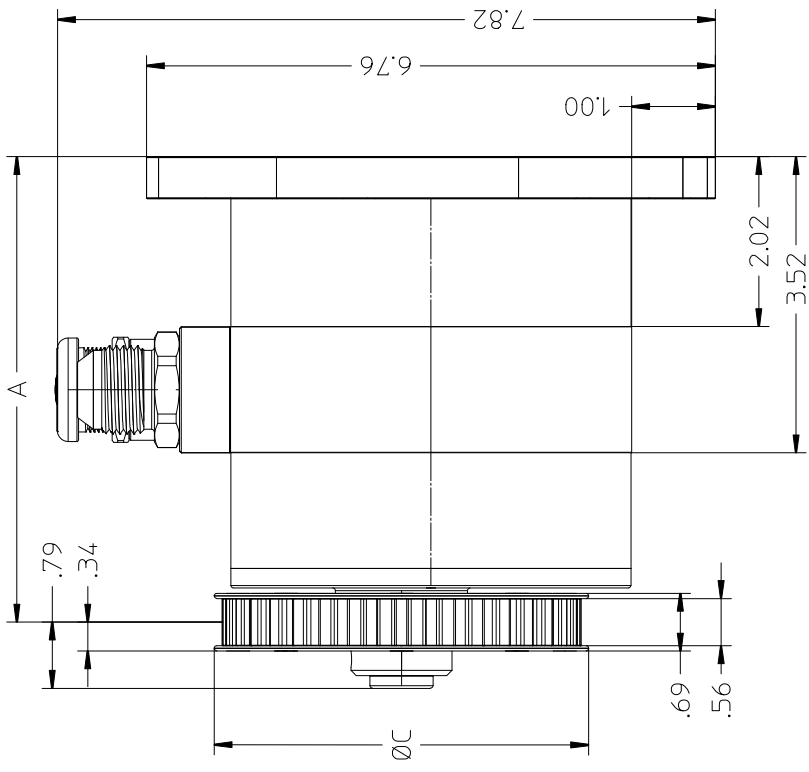
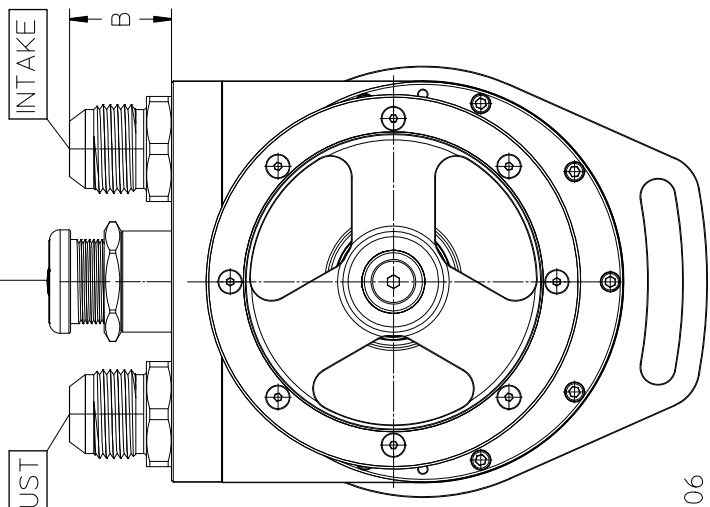

PULLEY	A DIM.	PULLEY REVERSED	B DIM.	C DIM.
GEN1 36 TOOTH STR.02.07.008	5.53"	16AN - 0.90" 12AN - 1.22"	4.45"	
GEN1 24T TOOTH STR.03.12.000	5.53"	16AN - 0.90" 12AN - 1.22"	2.98"	
GEN2 24T TOOTH STR.03.12.000	5.53"	16AN - 0.90" 12AN - 1.22"	2.98"	
GEN3 24T TOOTH STR.20.06.100	5.82"	16AN - 0.90" 12AN - 1.22"	3.10"	

2			
1			
0			

REVISION DESCRIPTION
 DESCRIPTION LAYOUT, MOUNTAIN MOTOR PUMP
 HEAT TREATING
 HARDNESS
 SURFACE PREPARATION
 FINISH

STAR MACHINE
 7810 OAK AVENUE
 PARKVILLE, MD. 21284

LINEAR (INCHES):
 0.05-10 ± 0.005
 11-20 ± 0.010
 21-30 ± 0.015
 31-40 ± 0.020
 41-50 ± 0.025
 51-100 ± 0.030

ANGULAR:
 9-80 ± 0.25°
 81-180 ± 0.50°
 181-270 ± 0.75°
 271-360 ± 1.00°

GEOMETRIC (INCHES):
 0.05-20 ± 0.005
 21-30 ± 0.010
 31-40 ± 0.015
 41-50 ± 0.020
 51-100 ± 0.025

TOLERANCES UNLESS SPECIFIED
 BREAK ALL EDGES UNLESS SPECIFIED

DESIGNED BY T HIGDON
 SCALE 1 OF 1
 SHEET SIZE B
 DRAWING NO. STR.02.07.000

DATE

THIS DRAWING IS THE PROPERTY OF STAR MACHINE.
 IT IS NOT TO BE REPRODUCED OR TRANSMITTED IN ANY FORM OR BY ANY MEANS WITHOUT THE WRITTEN AUTHORIZATION OF STAR MACHINE.