

VANE INSTALLATION

The vanes contain two long narrow faces.

One these faces is flat, the other has a radius.

Place the vanes into the slot of the rotor with the radiused face facing "out" in contact with the bore of the housing.

Once worn, the vanes cannot be turned over to be reused.

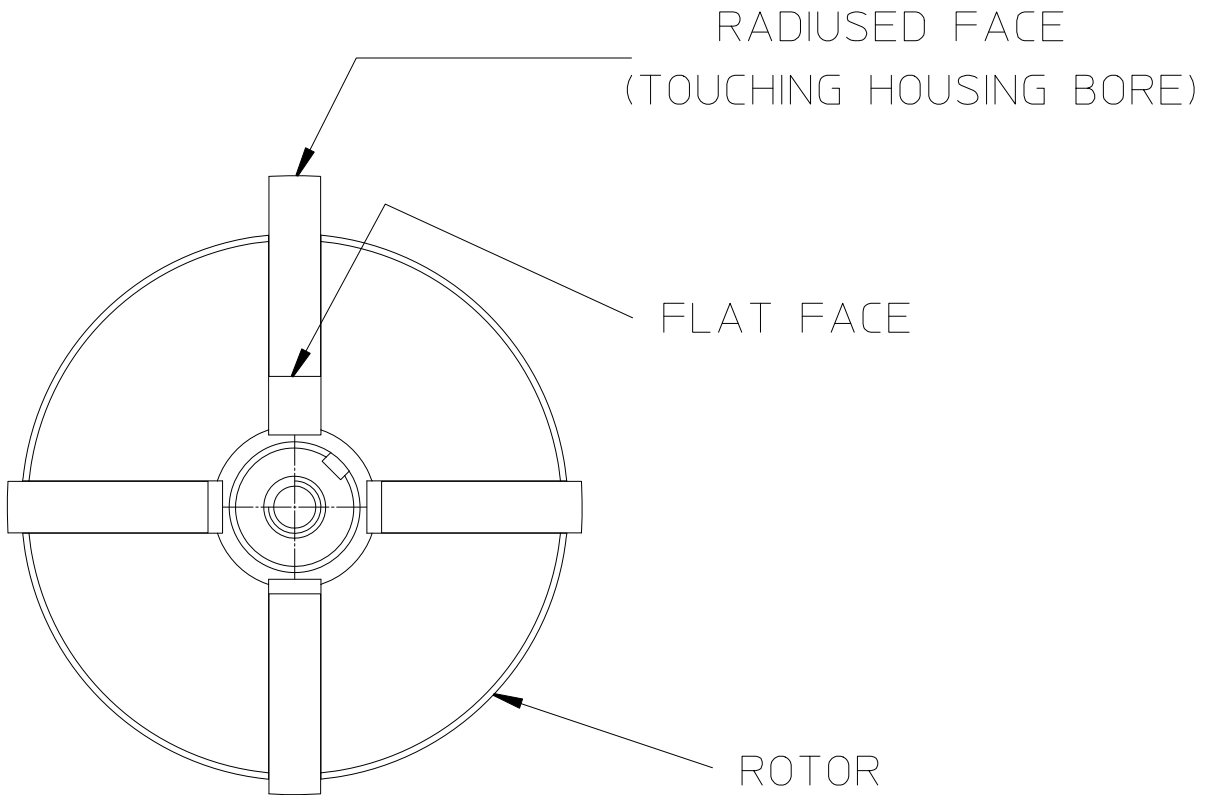

2		
1		
0		
REV.	REVISION DESCRIPTION	DATE

STAR MACHINE 7810 OAK AVENUE PARKVILLE, MD. 21234		DESCRIPTION		ORIENTATION, VANE	
		HEAT TREATING		MATERIAL	
HARDNESS		DEPTH		DESIGNED BY	
SURFACE PREPARATION		SCALE		T HIGDON	
FINISH		DRAWING NO.		SHEET 1 OF 1	
SIZE		A			

TOLERANCES UNLESS SPECIFIED		ANGULAR	
0.05--10 ± 0.005		0-90 ± 0.25°	
11---20 ± 0.010		91-180 ± 0.50°	
21---30 ± 0.015		181-270 ± 0.75°	
31---40 ± 0.020		271-360 ± 1.00°	
44---50 ± 0.030			
51--100 ± 0.050			

GEOMETRIC (INCHES)		BREAK ALL EDGES UNLESS SPECIFIED	
0.05-10 ± 0.005	0.05-20 0.005	0-100 0.015	
11---20 ± 0.010	21---40 0.010		
21---30 ± 0.015	41---50 0.015		
31---40 ± 0.020	51--100 0.020		
44---50 ± 0.030			
51--100 ± 0.050			

THIS DRAWING IS THE PROPERTY OF STAR MACHINE. IT SHALL NOT BE DISCLOSED OR COPIED WITHOUT THE WRITTEN AUTHORIZATION OF STAR MACHINE.